



#### ENGINE

Four stroke overhead valve petrol engine developing 11HP for exceptionally smooth and quiet operation. Optional. 6HP compact horizontal water cooled, 4 cycle, single cylinder diesel giving low operation noise, smooth running and low fuel consumption.

#### HYDRAULICS

A single pump supplies power to a composite valve featuring precise proportional flow for smooth and progressive control, in line flow control automatically restricts velocities to minimise shock and spillage. Hydraulic circuits divided to optimise power and smooth operation by pressure compensated preferential flow on demand. Filtered flow and return with replaceable cartridge on main flow. Oil cooler fitted as standard to diesel version.

#### TRACK DRIVE

Independent hydrostatic drive to each reinforced rubber track by high torque motors transferring power through hardened cast steel sprockets. Independent levers and hydraulic circuits permit accurate positioning of machine.

Travel speed (forward and reverse): 1.8 Km/H.

#### SWING / SLEW

Upper body rotation by an orbit rotor motor with integral automatic brake valve operating as the control lever is returned to neutral where the action is positive. Drive to the body is via fully enclosed induction hardened gears mounted on a single ball race. Precise proportional flow operating controls with shock absorbing valves in the swing circuits ensure smooth stop and start minimising operator fatigue. Unique "Zero" tail swing feature permits working alongside walls and in confined areas.

Swing speed : 9 RPM.

#### CONSTRUCTION

Very high specification all steel construction for long life in continuous heavy duty situations. Hardened lubricated pivot pins on boom, dipper and bucket pivots. Replaceable bolt-on hardened bucket teeth. Fully protected rams. Mounted on fabricated heavy duty chassis track frames fitted with 2 lubricated bottom rollers, mechanical track tensioning, and Rocoil shock absorbers. Optional hydraulically controlled variable width track base 30" - 40".



# POWERFAB

LIMITED

*The Better British Excavator...*

- **Zero Tail Swing**
- **Minimum Slew Radius 1066mm (42")**
- **Choice of Petrol or Diesel Engines**
- **360° Platform Swing**
- **0.8 Tonnes Tear Out Force**
- **0.88 Tonnes Operating Weight**

# 1000X



## GENERAL SPECIFICATIONS

### ENGINE

	Standard Petrol	Option Diesel
Model:	Honda GX340.	Kubota EB300SAE
Capacity:	337cc	309cc
Bore/Stroke:	82 x 64mm	75 x 70mm
Net continuous power:	10HP @ 3600 RPM	6HP @ 3000RPM
Net continuous torque:	240kg.cm @ 2500RPM	1.83kg.m @ 2400RPM
Battery:	12 volt 55Ah	12 volt 45Ah Electric Start

### HYDRAULICS

Hydraulic pump outputs:	28.8 LPM
Main relief valve setting:	138 Bar.
Hydraulic motors:	Travel, two high torque axial piston with counter balance valve. Swing, Orbit rotor motor with counter balance brake valve.
Cylinders 4 off:	Boom 2.375" x 15" stroke. Dipper 2.0" diameter 15" stroke. Bucket 2.0" diameter x 13" stroke. Dozer blade 2.375" diameter x 3" stroke.
Mass:	Operating; 0.88 tonnes.
Capacity:	Powerfab 12" (standard) bucket; 0.033 cm SAE (0.029 cm GECE) Tear out force 0.8 tonnes at root of bucket teeth.

### Digging dimensions - Maximum:

Height:	2.133 m
Dump height:	1.524 m.
Depth:	1.796 m
Vertical dig:	1.0 m
Radius:	2.856 m
Tail swing:	0.495m (within tracks at all angles of swing)
Dozer:	1000mm x 230mm Std. Lift 180mm, Drop 130mm.
Gradeability:	58% (30°)
Noise:	LWA 103 & LPA 90
Tracks:	200mm wide steel reinforced heavy duty continuous rubber.
Ground pressure:	0.183 Kgf/cm sq.
Buckets:	6" 9" 12" 16" 24" digging.

Dimensions: mm (inch)

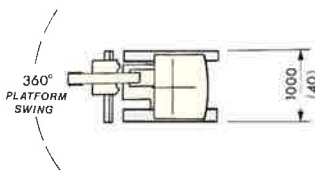
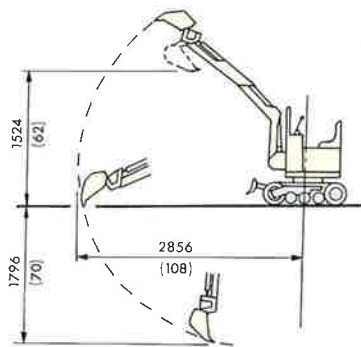
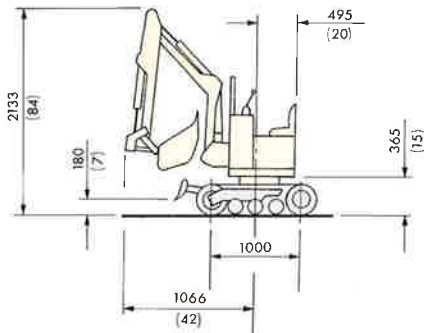

DEALER:

# POWERFAB

*The Better British Excavator...*

POWERFAB LIMITED, FAIRVIEW, ASHVALE, TREDEGAR, GWENT NP23HA.  
Tel: 0495 723083 (7 lines). Fax: 0495 718162.

Due to our policy of continual improvement, we reserve the right to amend the design or specification without prior notice.  
Patents Pending.  
© POWERFAB LIMITED