

# ROUGHNECK 2000

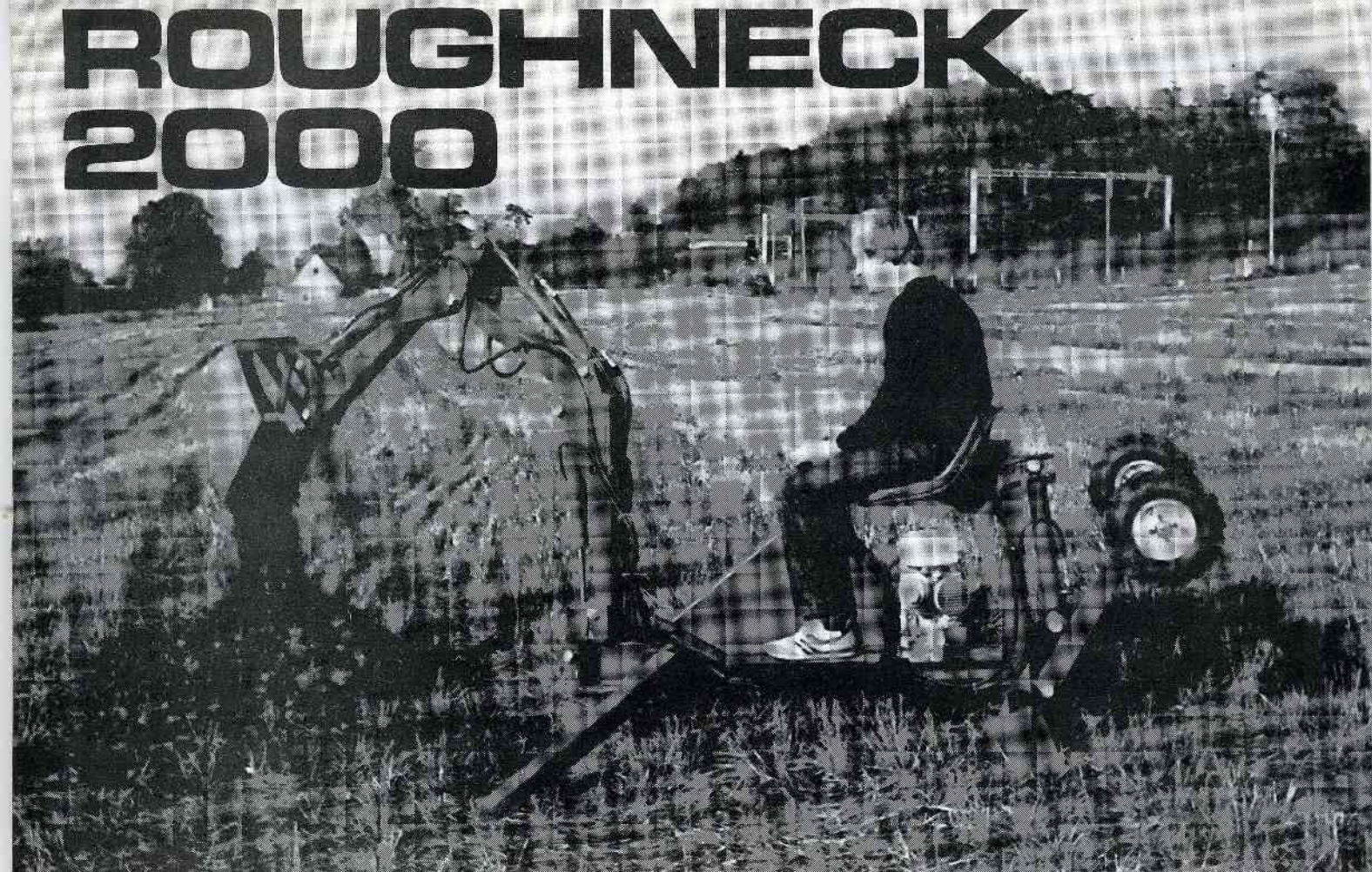

## BRITISH BUILT MICRO - EXCAVATOR

- \* 2 METRE DIGGING DEPTH
- \* PASSES THROUGH 2'6" DOORWAY
- \* EASILY ROAD TRAILABLE
- \* POWERFUL HYDRAULICS
- \* SITE READY IN MINUTES
- \* EXCAVATES ALONGSIDE WALLS
- \* EASILY MANOEUVREABLE,  
WALKS ITSELF AROUND SITE



- \*A British designed and built Micro - Excavator, Which features deep digging capabilities to 2 metres, ability to pass through a standard door opening and dig alongside a wall.
- \*Ease of operation via a powerful integrated petrol driven hydraulic power pack.
- \*Easily road trailable, the **ROUGHNECK** Excavator is site ready in minutes.
- \*Economic purchase, low running costs, ideal for small builders, plant hire, horticulture, etc.
- \*A range of buckets from 200mm trenching to 1 metre backfill blade ensures versatility.

## **ROUGHNECK EXCAVATORS LIMITED**

KINGS LANGLEY,  
HERTS, ENGLAND.

DISTRIBUTOR:

**ROUGHNECK EXCAVATORS LTD.**  
WESTMINSTER WORKS  
SANDOWN ROAD  
WATFORD HERTS.  
WD2 4UB  
TEL WATFORD 49990

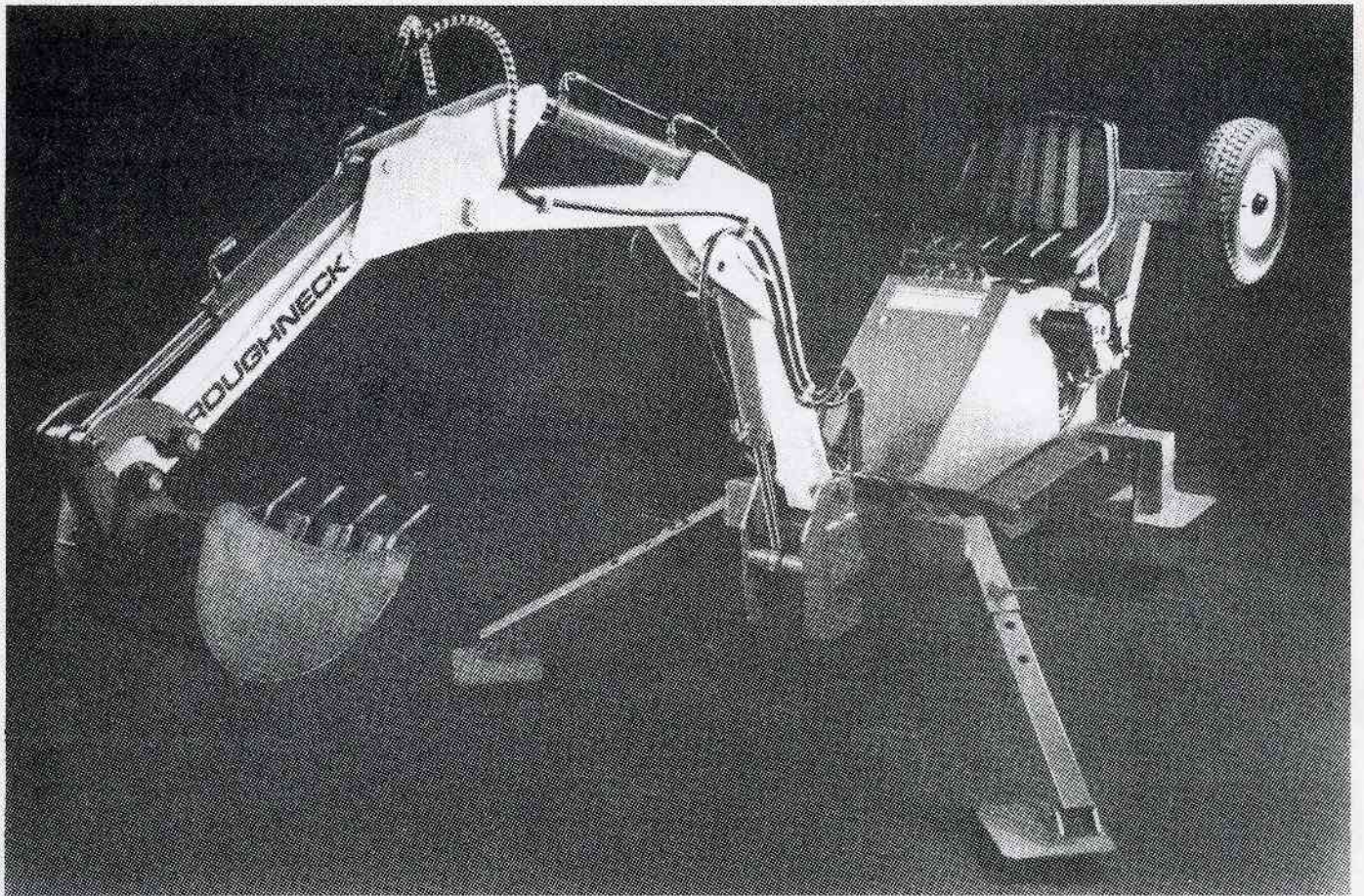

## The 2000 range

2000 - TRAILER MOUNTED MICRO EXCAVATOR

2000T - SELF TRAILERING MICRO EXCAVATOR

2000 LASER - TRAILER MOUNTED OR SELF TRAILERING MICRO EXCAVATOR, FITTED PETROL 10 H.P. ENGINE OR DIESEL 8½ H.P. ENGINE, FORCED AIR COOLER, 21 LPM GEAR PUMP & QUICK RELEASE COUPLING FOR AUXILIARY TOOLS.

- QUICK RETURN ON INVESTMENT
- LOW PURCHASE COST
- LOW MAINTENANCE REQUIREMENTS
- HIGH PERFORMANCE SOLUTION TO TOUGH DIGGING JOBS.
- SUPERIOR ENGINEERING FOR LONG LIFE
- EASY TO OPERATE

For colour brochure, prices, etc  
'phone (0923) 49990 today

Manufactured by:-  
Roughneck Excavators Limited  
Westminster Works,  
Sandown Road  
Watford, Herts WD2 4UB  
Telephone: Watford (0923) 49990/51939  
Telex: 923326

Member of Multiple Industries Group

**ROUGHNECK**<sup>TM</sup>  
**2000** Designed to make the  
pick & shovel obsolete.

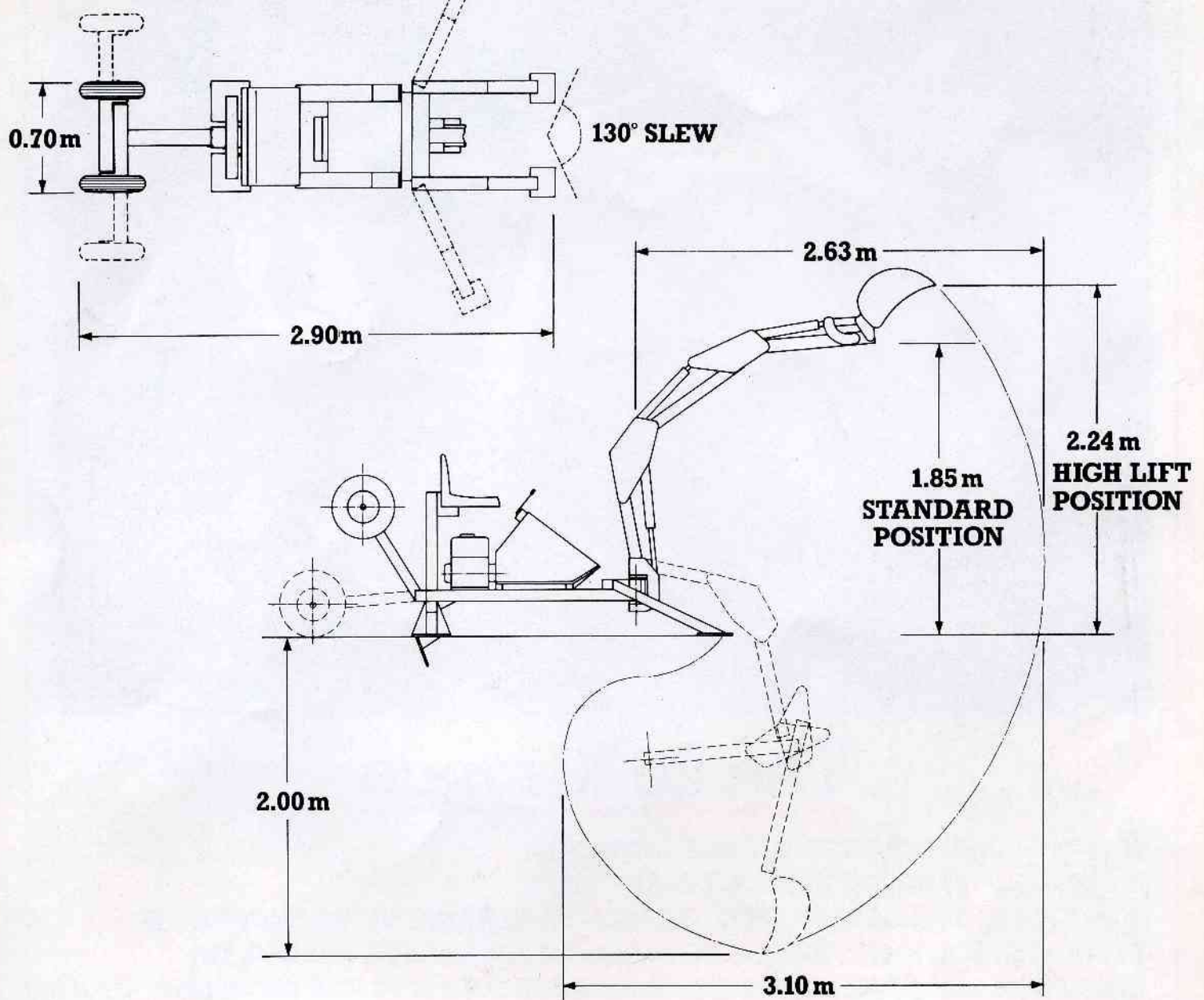

## Specification

- Engine:** 5 hp — 4 stroke
- Hydraulics:** Rugged integrated power unit featuring in line gear pump producing 2 GPM flow. Factory pre-set relief valve to protect hydraulic system. Heavy duty, high quality honed bore cylinders with chromed rods and scraper seals for exceptional performance under the most arduous conditions. Spherical self aligning bearing at each end.
- Chassis:** Heavy duty hot rolled steel, fully welded. Pivot Points: High carbon steel pins — re-greasable. Weights: Roughneck digger 400 kg Trailer 80 kg
- Shovel:** 16", fitted as standard

## Optional Equipment

- Engine: Diesel
- Buckets: 8', 12', 16' and 24'
- Clay spade, Ditching bucket, Vee bucket.
- Face shovel, Levelling blade, Side cutters.
- Narrow access wheels.
- Rubber feet for working on hard surfaces.
- Weather cover.

## ROUGHNECK EXCAVATORS LIMITED

Westminster Works,  
Sandown Road,  
Watford, Herts. WD2 4UB

Telephone: Watford (0923) 49990/51939  
Telex: 923326

Member of Multiple Industries Group

Dealer:

Roughneck Excavators Limited reserve the right to amend prices and/or specifications without prior notice.

# ROUGHNECK

## 2000T-2600T EXCAVATOR

Powerful, tough, well engineered excavators, for performance and versatility.

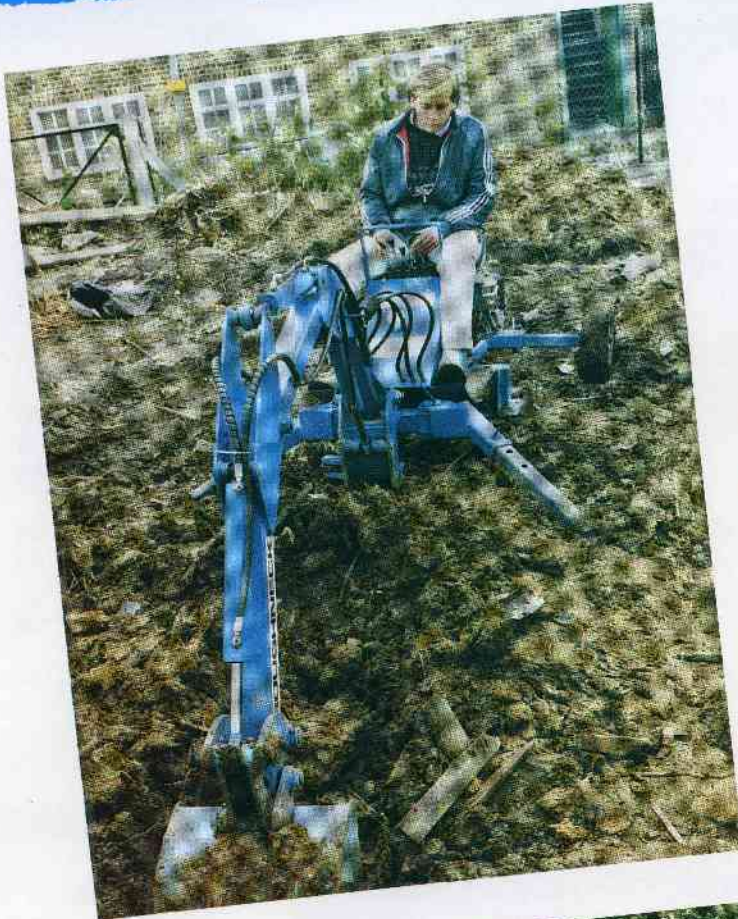

- Backhoe features full bushing and greasing points.
- Telescopic two position, rear axle and adjustable outrigger legs.
- Large volume buckets for high work rate.
- Goes through 2'6" opening.
- Digs up against a wall.
- Climbs hills.
- Negotiates low walls.
- Quick return on investment.
- Low purchase cost.

- High performance solution to tough digging jobs.
- Low maintenance requirements.
- Superior engineering for long life.
- Easy to operate.
- Hydraulic leg option.
- Power take-off option.
- Large range buckets.
- Self trailering.



Six Months Warranty

**ROUGHNECK FOR RELIABILITY**

# GENERAL SPECIFICATION 2000T-2600T EXCAVATORS

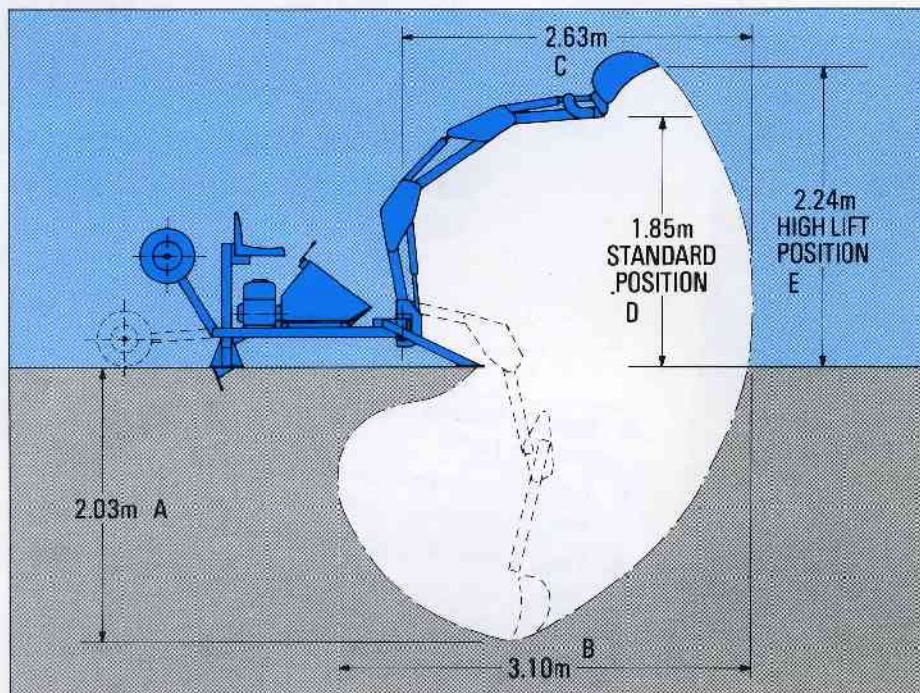

## 2000T

Digging depth	A = 2.03m
Length of dig	B = 3.10m
Outreach	C = 2.63m
Lift height Std	D = 1.85m
High lift position	E = 2.24m
Tearout	1.75 tons
Std weight	460 kgs
Weight of self trailering	520 kgs

## 2600T

Digging depth	A = 2.70m
Length of dig	B = 4.27m
Outreach	C = 3.80m
Loadover height (maximum with hydraulic legs)	2.34m
Tearout	2.1 tons
Std weight	520 kgs
Weight self trailering	600 kgs

## SPECIFICATION

**ENGINE:** 4 stroke — 8 h.p.

**HYDRAULICS:** Rugged system featuring in line gear pump. Factory pre set relief valve to protect the hydraulic system. Backhoe cylinders protected by full service line relief protection. Heavy duty, high quality honed bore cylinders with chromed rods and scraper seals for exceptional performance with spherical self aligning bearings.

**CHASSIS AND BACKHOE:** Heavy duty hot rolled steel sections, fully mig welded. High carbon steel pins and hard nylon replaceable bearings throughout.

## OPTIONAL EQUIPMENT

**ENGINE:** 5 h.p., 7.2 h.p., 11 h.p. and diesel

**BUCKETS:** 8", 12", 16" and 24"

Bolt on levelling blade, side cutters, narrow access wheels, central spade, weather cover, hydraulic legs, hydraulic power take-off and cooler, hydraulic tools.

Manufactured in Great Britain by  
**ROUGHNECK EXCAVATORS  
LIMITED**

Gazelda Industrial Estate  
Lower High Street  
Watford  
Herts

Telephone: Watford (0923) 49990  
Telex: 923326

Roughneck Excavators Limited reserve the right to amend prices and/or specifications without prior notice.